

4/S1
v 3.3 (en)

VENTILATION LOUVRES

FZ, AFZV, AFZM, RZ, ARZ, PZ, ZP



TABLE OF CONTENTS

Ventilation louvre FZ and AFZV.....	241
Ventilation louvre AFZM and RZ.....	242
Ventilation louvre RZO and ARZ.....	243
Ventilation louvre PZ.....	244
Ventilation louvre ZP.....	245
Selection diagrams.....	246
Ordering key.....	247

FZ | AFZV

- FZ - made out of galvanized steel sheet
- AFZV - made out of aluminium profiles
- Galvanized steel mesh on the back side
- Fixing with screws

Options:

- Installation subframe
- RAL...

* Holes for screws are not drilled

Standard dimensions FZ, AFZV*

B	385 - 1885 mm, in increments 200mm
H	300 - 1800 mm, in increments 150mm

*all combinations B x H are possible

Free cross-section approx. 60 % of B x H

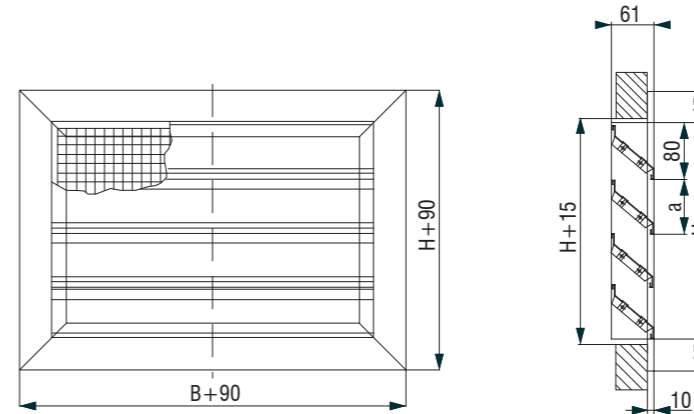

Dimension B > 1885 mm or H > 1800 mm

$$B = 2B1 + 90; H = 2H1 + 90$$

Example :
B = 1785 mm
H = 3400 mm

$$H1 = (H - 90) / 2 = (3400 - 90) / 2 = 1655$$

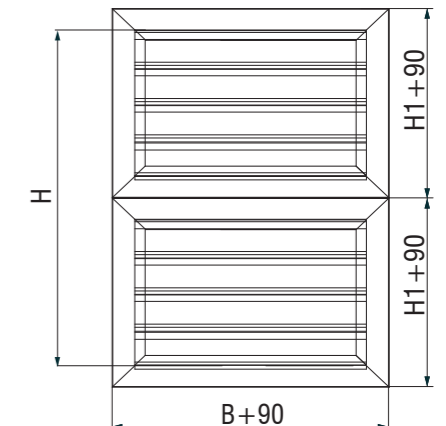
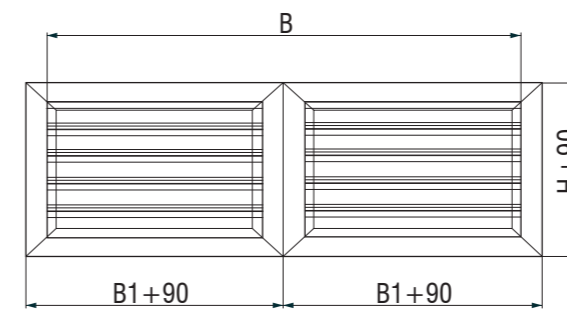

Definition of symbols:

V [m³/h]	- Air flow	v _h [m/s]	- Average core velocity at distance h (m) from a diffuser
V [m³/h]	- Nominal air flow	Δp [Pa]	- Total pressure drop
V _{uk} ⁿ [m³/h]	- Total air volume in motion	t _p [°C]	- Air temperature in a room
h [m]	- Distance from the ceiling to the occupied zone	t _z [°C]	- Supply air temperature
H [m]	- Room height	t _m [°C]	- Core air temperature
A, B [m]	- Distance between diffusers	Δt _z [°C]	- (t _z - t _p)
x [m]	- Distance from wall	Δt _L [°C]	- (t _m - t _p)
L [m]	- Throw distance (x+h)	i	- Induction V _{uk} /V
A _{ef} [m²]	- Effective discharge area	L _{WA} [dB(A)]	- Sound power level
v _{ef} [m/s]	- Effective jet velocity		
v _L [m/s]	- Average core velocity at distance L (m) from a diffuser		
v _{Lmax} [m/s]	- Maximum core velocity at distance L (m) from a diffuser		

AFZM

- Made out of anodized aluminium profiles
- Galvanized steel mesh on the back side
- Fixing with screws

Options:

- Installation subframe (UR)
- RAL...

Standard dimensions AFZM*

B	297 - 1197 mm, in increments 100mm
H	197 - 697 mm, in increments 100mm

*all combinations B x H are possible

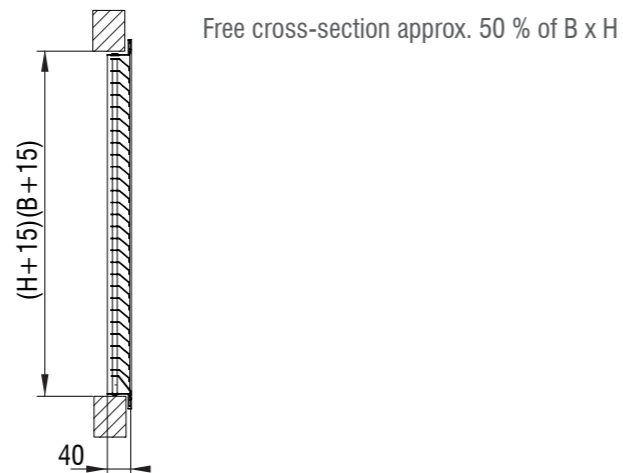
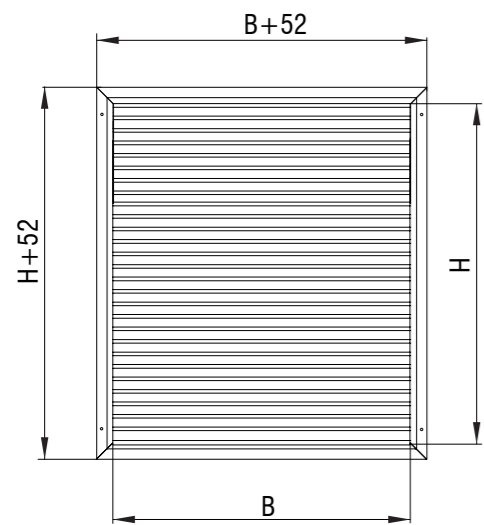

ZRZ12 / RZ12

- RZ - made out of galvanized steel sheet, gears and bearings made of ABS.
- Opposed damper blade operation
- $\Delta p_{max} = 1000 \text{ Pa}$; $t_{max} = 70^\circ\text{C}$

Standard dimensions RZ*

B	200 - 1400 mm, in increments 100mm
H	215 - 1015 mm, in increments 100mm

*all combinations B x H are possible

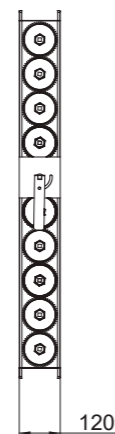
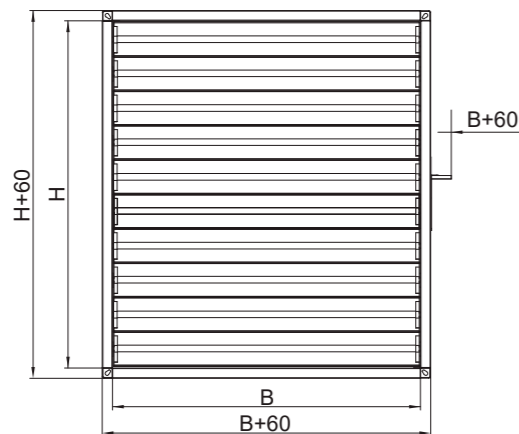

ARZ

- Made out of anodized aluminium profiles, gears and bearings made of ABS.
- Opposed damper blade operation
- Blade tip seals, made of specially profiled rubber provides excellent sealing characteristics
- $\Delta p_{max} = 600 \text{ Pa}$; $t_{max} = 70^\circ\text{C}$

Standard dimensions ARZ*

B	400 - 2400 mm, in increments 200mm
H	210 - 1510 mm, in increments 100mm

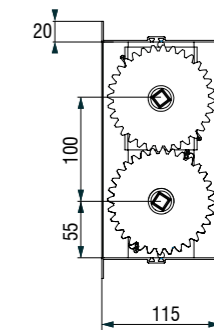
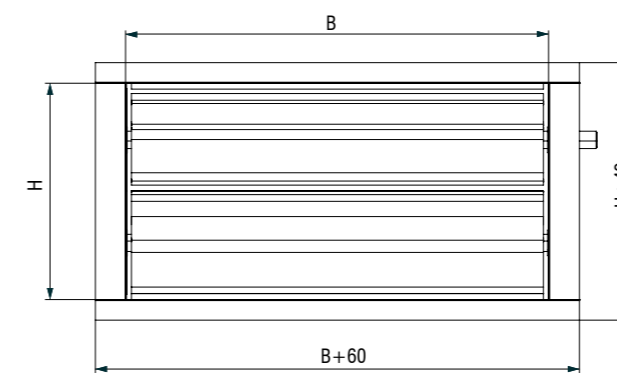

RZO

- Reinforced regulation louvre
- Made out of steel sheet profiles, reinforced damper blades out of steel profiles, brass bearings
- Frame width RZ012 - 120 mm
RZ018 - 180 mm
- Counter-rotating damper blades

Standard dimensions RZ*

B	400 - 2000 mm, in increments 200mm
H	345 - 1995 mm, in increments 195mm

*all combinations B x H are possible

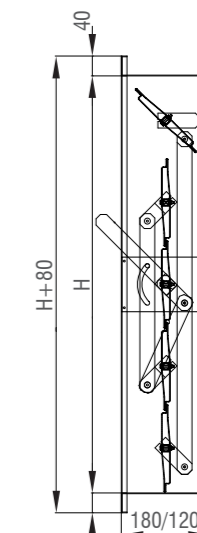
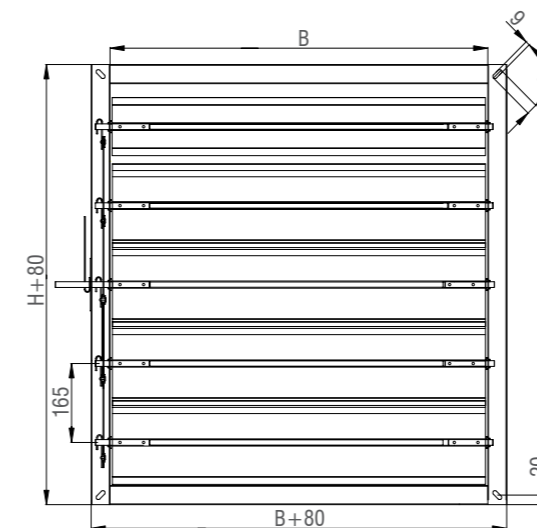



PZ

- Frame made of anodized aluminium profiles, blades made from anodized aluminium sheet.
- Duct version - frame made of galvanized steel sheet
- Wall or duct installation with screws

Options

- Overpressure (Supply)
- Underpressure (Exhaust)
- Duct type
- Discharge with square-to-cylindrical transition section
- Installation subframe

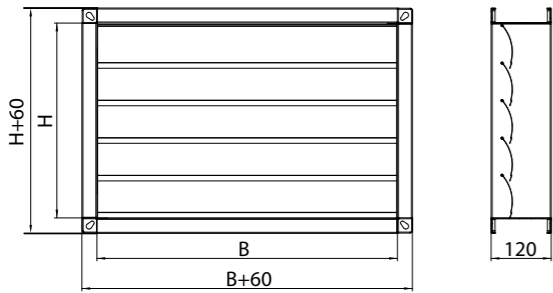

PZ-K

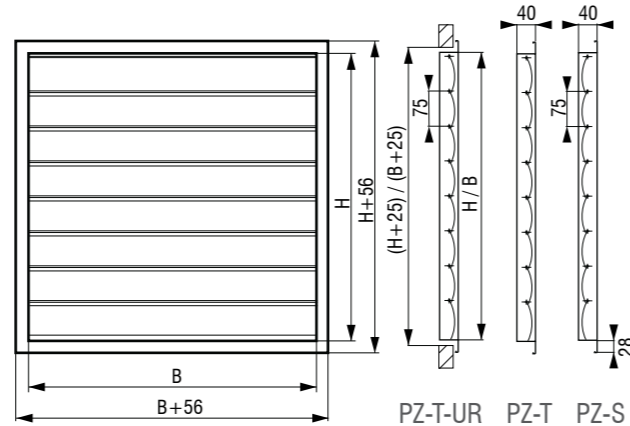

PZ-T-UR PZ-T PZ-S

Standard dimensions PZ-T, PZ-S, PZ-K*

B	200 - 1600 mm, in increments 200mm
H	240 - 1590 mm, in increments 75mm

*all combinations B x H are possible

Standard dimensions PZ-T/O*

B	330 - 730 mm, in increments 50mm
∅D	300 - 700 mm, in increments 50mm

*all combinations B x H are possible

OVERPRESSURE

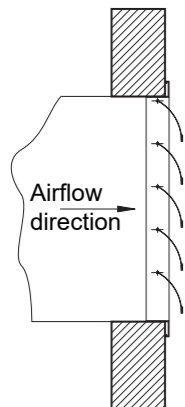

UNDERPRESSURE

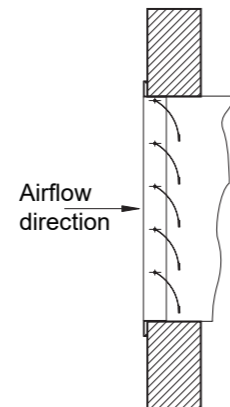

ZP

- Made of galvanized steel sheet
- Installed directly into the wall opening by anchor springs at the installation frame

Application

- Separation of sand from air stream
- Correct mounting position of the sand-trap louver is important
- Average efficiencies obtained by tests 80% particles 20 - 50 μm, or 50% particles 1 - 70 μm.

Options

- RAL...

Standard dimensions ZP*

B	300 - 2250 mm, in increments 150mm
H	300 - 2250 mm, in increments 150mm

*all combinations B x H are possible

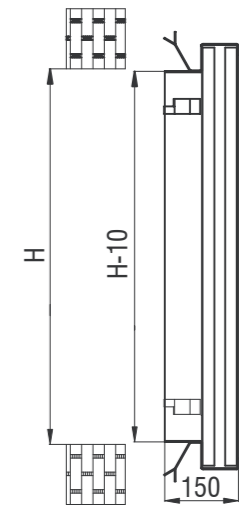
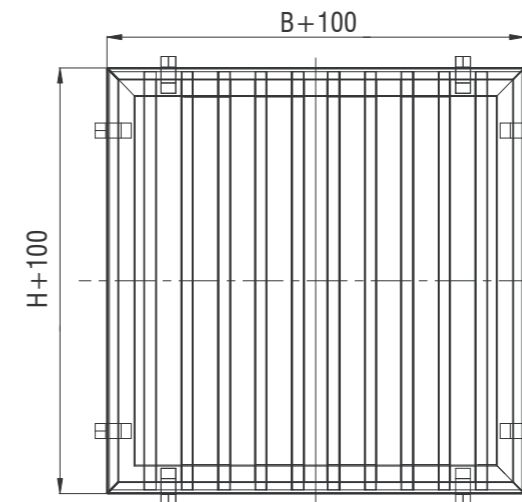

Vertical connection of two sand trap louvers

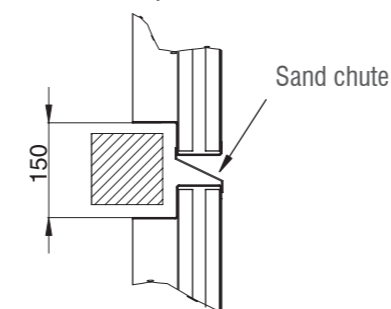

SELECTION DIAGRAMS

Pressure drop diagram - FZ

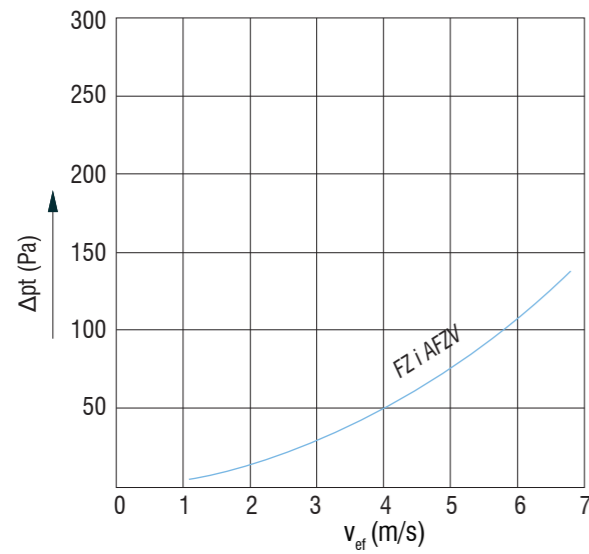

Pressure drop diagram - AFZM, AFZV

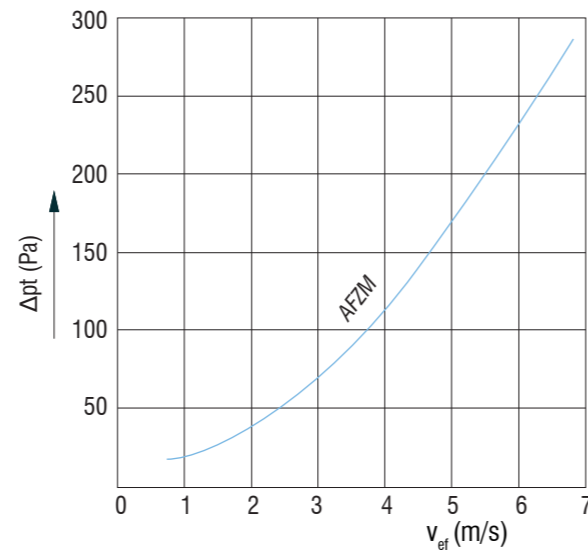

Flow resistance diagram - FZ

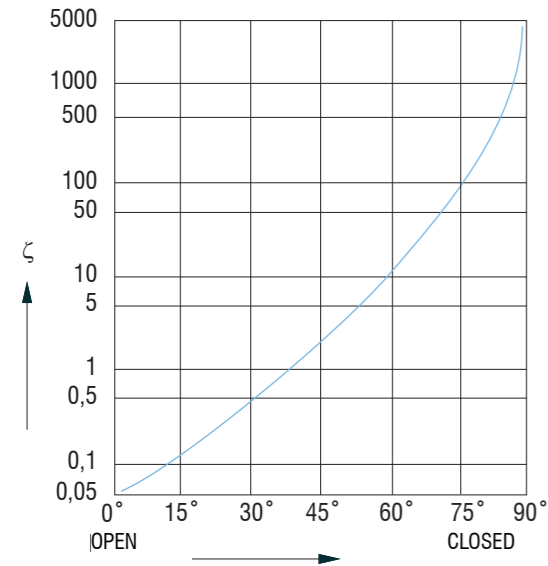

Flow resistance diagram - ARZ

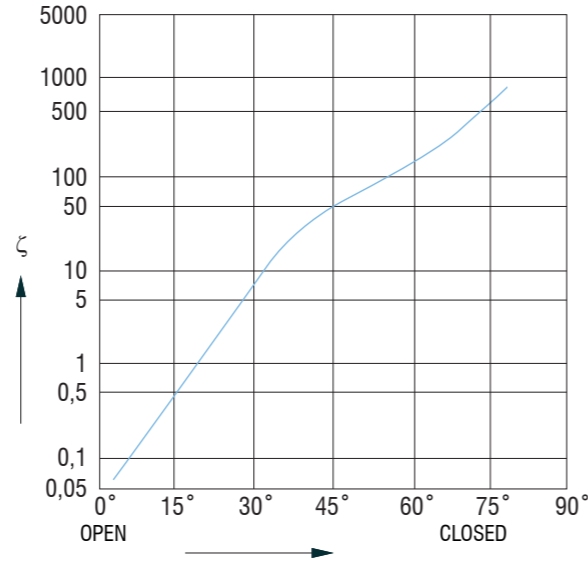

Pressure drop diagram - PZ

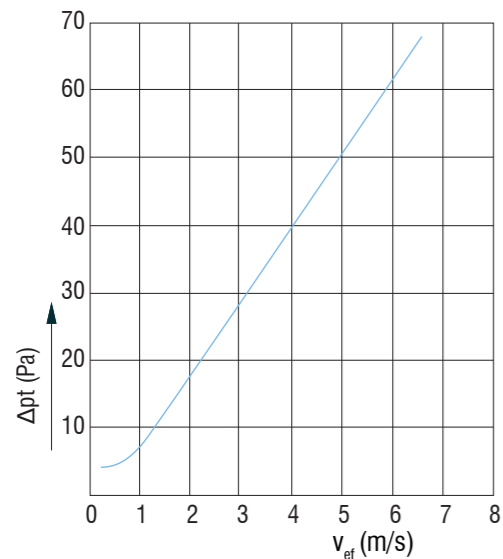

Flow resistance diagram - ZP

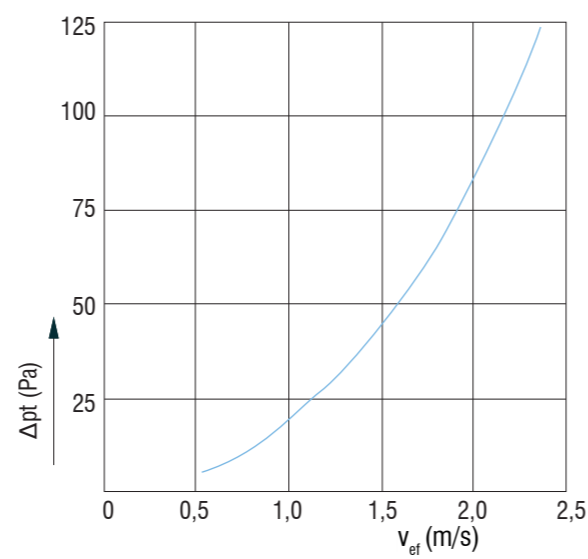

ORDERING KEY

Louvre type	AFZM - 1785X1500 - UR - M²30 - OZ
	FZ, AFZV, AFZM, RZ12, RZO, ARZ, PZ-T, PZ-S, PZ-K, PZ-T/O, ZP
Dimensions	
Installation subframe (UR, IS)	
Drive (RZ, ARZ)	
	- R , manual
	- M 24 , motor actuator 24 V
	- M 230 , motor actuator 230 V
Regulation (RZ, ARZ)	
	- OZ (two positions)
	- K (continuous)
	- F (return spring)

* Screws are not delivered